

# Saint Roch

## Cast Iron Boilers



### Saint Roch Universal Boiler 3-6 Section Boilers

Boiler Manual And Installation  
Instructions for Atmospheric Venting  
(See Direct Venting addendum for Direct Vent installation)

**Please Read Instructions Carefully  
Save for Future Reference**

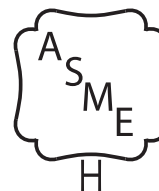

Conforms to UL Std. 726

#### Danger

##### WHAT TO DO IF YOU SMELL GAS:

- Do not try to light any appliance
- Do not touch any electric switch; do not use any phone in your building
- Immediately call your gas supplier from a neighbor's phone. Follow the gas supplier's instructions.
- If you can not reach your gas supplier call the fire department
- Installation and service must be performed by a qualified licensed installer, service agency or the gas supplier.

#### WARNING

If the information in this manual is not followed exactly, a fire or explosion may result causing property damage, personal injury or loss of life.

Manufactured by:  
SAINT ROCH S.R.L  
ITALY

Distributed By:  
QHT, INC.  
3560 LAFAYETTE ROAD  
BLDG. 2, UNIT A  
PORTSMOUTH, NH 03801  
PHONE: 603-334-6400 FAX: 603-334-6401  
REV. 2/25

Dear Customer

Dear Customer,

Thank you for purchasing a Saint Roch “UNIVERSAL” SERIES Boiler.

The Universal series boiler, with its triple-pass design and low water content, features an upper cylindrical coil chamber that quickly supplies heat to an internal coil for Domestic Hot Water (DHW) production—making it truly UNIVERSAL. Designed to be lighter, more efficient, and more durable than other tankless boilers, the SRU series ensures optimal performance.

Equipped with the Hydrolevel 3250TC “Fuel Smart” controller, this boiler intelligently regulates fuel consumption by adjusting the burner operation based on your heating demands and usage patterns, improving efficiency during inactive periods.

While this manual provides essential information about your Universal series boiler, it does not cover all aspects of installation and operation. Reading it does not replace the expertise of a qualified, licensed heating contractor. If you have any questions regarding your boiler’s performance, we encourage you to contact your installing contractor, dealer, or our support team. Additionally, we require your contractor to perform efficiency tests using proper instruments and document the burner’s performance on page 19.

The controls and accessories referenced in this manual serve as general guidelines rather than strict recommendations. While alternative makes and models may be suitable, your installing contractor is best equipped to determine the specific needs of your system and the availability of components in your area. However, certain components—such as the Hydrostat 3250 overheat control and the pressure relief valve—are essential for safe operation and must be installed as supplied.

Every Saint Roch boilerblock is built in compliance with the ASME Boiler and Pressure Vessel Code and proudly bears the “H” stamp. The Universal boiler series comes with a limited lifetime warranty (see the back of this manual for details). To activate your warranty, please complete the registration form on our website ([www.saintroch.us](http://www.saintroch.us)), providing the boiler serial number (found on the bottom draw rod), the installation date, and your installer’s name.

We appreciate your trust in Saint Roch and your choice of the Universal Boiler. Should you have any questions or feedback, please don’t hesitate to contact us.

Sincerely yours,  
Jim Quincy  
President, QHT Inc.

## Table of Contents

	Section	Page
Important Information and Warnings		4,5
Homeowner Information For Gas		6
General Information	1	7
Boiler Block Assembly	2	8
Boiler Location	3	9
Installation of Boiler Trim Kit Components	4	10,11
Tankless Coil Installation	5	12,13
Piping The Boiler	6	14
Intake Venting	7	15,16
Exhaust Venting	8	17
Common Exhaust Venting	8.1	18
Gas Venting	8.2	18
Burner Setup	9	19
Oil Burner Setup	9.1	20
Gas Burner Setup	9.2	21
Gas Line Piping	10	22
Boiler Casing Assembly	11	23
Baffle Installation	11.1	24
Wiring	12	24
Wiring Hydrostat Control	12.1	25
Oil Diagrams	12.2	26
Gas Diagrams	12.3	27
Smart Domestic Economizer	13	28
Commissioning the Boiler	14	29
Maintenance	15	29
Installer Notes	16	30
Warranty		31

**⚠ WARNING**  
**IMPORTANT INFORMATION**  
**Please read this page carefully.**

**Homeowner:**

- For homeowner or person responsible for simple start-up and routine maintenance of the system. Instructions must be followed to assure proper operation of your boiler.

**In addition, it is your responsibility to:**

- Have boiler and burner installed by a qualified installer.
- Have boiler and burner serviced annually by a qualified service technician.
- Review and understand start-up and routine maintenance procedures with qualified service technician.
- Perform routine maintenance as described on page 29

**Service Technician:**

- For a qualified service technician who has the necessary equipment to check the boiler and system performance, and is responsible for start-up and service of boiler and system.
- All instructions in this manual must be followed to assure proper operation of this boiler.
- Annually service boiler and burner to assure proper operation. See page 29 for service record.
- Review and explain start-up and routine maintenance procedures with homeowner.

**⚠ WARNING**

**⚠ WARNING**

**⚠ WARNING**

- Fire, explosion, asphyxiation and electrical shock hazard. Improper installation could result in death or serious injury. Read this manual and understand all requirements before beginning installation.
- Modification, substitution or elimination of factory equipped, supplied or specified components could result in death or serious injury.
- Installation or venting a boiler or any other oil appliance with improper methods or materials may result in serious injury or death due to fire or to asphyxiation from poisonous gases such as carbon monoxide which is odorless and invisible.
- Fire, Explosion, Asphyxiation, Electrical shock hazard, Flooding will result in damages such as electrical problems, corrosion, inoperative parts, mold and other unforeseen issues which can occur over time. Any equipment determined by a professional as damaged by a flood, defined as excess of water or other liquid, shall be replaced. Failure to follow these directions will result in a Hazardous Situation.

**⚠ WARNING**

**Symptoms of CO poisoning include the following:**

- |                                 |                           |
|---------------------------------|---------------------------|
| • <b>dizziness</b>              | • <b>unclear thinking</b> |
| • <b>vision problems</b>        | • <b>nausea</b>           |
| • <b>shortness of breath</b>    | • <b>weakness</b>         |
| • <b>headache</b>               | • <b>unconsciousness</b>  |
| • <b>loss of muscle control</b> |                           |

IF ANY OF THE SYMPTOMS OCCUR, VACATE THE PREMISES IMMEDIATELY AND CONTACT A QUALIFIED HEATING SERVICE COMPANY, THE GAS COMPANY OR THE FIRE DEPARTMENT.

**United States installations must comply with:**

- State and local plumbing, heating and electrical codes.
- National codes where applicable.
- Standard for Controls and Safety Devices for Automatically Fired Boilers, ANSI/ASME CSD-1, – latest edition, when required.
- National Electrical Code, ANSI/NFPA 70, – latest edition and any additional national, state or local codes.

**⚠ WARNING**  
**IMPORTANT INFORMATION**  
Please read this page carefully.

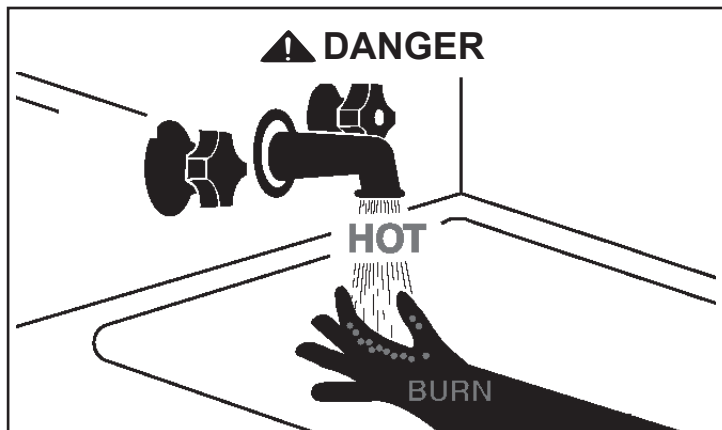

**CAUTION**  
Increasing the thermostat setting above the pre-set temperature may cause severe burns and consume excessive energy. Hotter water increases the risk of scald injury.

**IMPORTANT**  
RISK OF SCALDING. Hot water will cause third degree burns in 6 seconds at 60°C (140°F), in 30 seconds at 54°C (130°F).

**⚠ WARNING**

Water heated to temperature for clothes washing, dish washing and other sanitizing needs can scald and cause permanent injury.

Children, elderly, or physically handicapped persons are more likely to be permanently injured by hot water. Never leave them unattended in bathtub or shower. **Never allow small children to use a hot water tap or draw their own bath.**

If anyone using hot water in the building fits the above description, or if state laws or local codes require certain water temperatures at hot water taps, you must take special precautions:

- Use lowest possible temperature setting.
- Install some type of tempering device, such as an automatic mixing valve, at hot water tap or water heater. Automatic mixing valve must be selected and installed according to manufacturer's recommendations and instructions.
- Water passing out of drain valves may be extremely hot. To avoid injury:
- Make sure all connections are tight.
- Direct water flow away from any person.

# HOMEOWNER INFORMATION FOR GAS

## TO START UP THE APPLIANCE

1. STOP! Read the safety information on the side of the boiler. DO NOT START THE BOILER UNLESS ALL CLEANOUT DOORS ARE SECURED AND SEALED. (Skip to step 9 for oil burning boilers)
2. Set thermostat to lowest setting
3. Turn off all electric power to the appliance
4. Do not attempt to light the burner by hand
5. Turn the manual shut off on the combination gas valve clockwise to the off position.
6. Wait five minutes to clear out any gas. Then smell for gas, including near the floor.

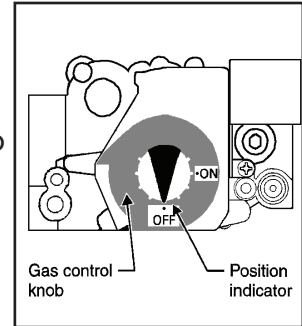

## If you smell gas, STOP!

- Do not try to light any appliance
  - Do not touch any electric switch; do not use any phone in your building
  - Immediately call your gas supplier from a neighbor's phone. Follow the gas supplier's instructions.
  - If you can not reach your gas supplier call the fire department
7. If you don't smell gas, go to the next step.
  8. Return the manual valve on the combination gas valve to the on position by reversing step "5".
  9. Turn on all electric power to the appliance.
  10. Set thermostat to the desired setting.
  11. If the burner fails to light you may press the reset button once. If the appliance will not operate, follow the instructions "To Turn Off Gas To Appliance" and call your service technician or gas supplier. DO NOT ATTEMPT TO START THE BURNER WHEN EXCESS GAS HAS ACCUMULATED, WHEN THE UNIT IS FULL OF VAPOR, OR WHEN THE COMBUSTION CHAMBER IS VERY HOT.

NOTE: ALWAYS KEEP THE MANUAL FUEL SUPPLY VALVE SHUT OFF IF THE BURNER IS SHUT DOWN FOR AN EXTENDED PERIOD OF TIME.

## TO TURN OFF GAS APPLIANCE

Set the thermostat to the lowest setting.  
Turn off electric power to the appliance if service is to be performed.  
Turn the gas control valve to the off position.

# 1. General Information

The SRU series boilers are wet base design, sectional, cast-iron boilers for forced hot water heating systems. The boilers are shipped pre-assembled from the factory in lengths from three to six sections. They are designed for firing with oil or gas power burners, which are packed separately along with the jacket and controls for shipping purposes.

When the boiler is received, check the contents to ensure that there is no shortage or damage to any part of the boiler system. With every boiler, you should receive a boiler block, jacket, trim kit and a burner (oil or gas).

**USE ONLY THE UL LISTED BOILER COMPONENTS AND UL/CSA LISTED OIL OR GAS BURNER COMPONENTS SUPPLIED WITH THE BOILER SYSTEM.**

## Energy Star Compliant Ratings



Product Code	Number of Sections	Heating Capacity (MBH)	INPUT (MBH)	Net AHRI Rating Output	Length (Inch)	Coil Size (GPM)	Water Content (gal)	Weight (Lbs)	AFUE Efficiency (%)
SRU30	3	123	140	107	24.5"	3.5	11.25	337	87.1
SRU40	4	154	175	134	29.5"	4.5	14.125	425	87.1
SRU50	5	185	210	161	34.5"	5	17	509	87.2
SRU60	6	216	245	188	39.5"	5	19.875	599	87.3

E designates ENERGY STAR compliant ratings @ 87%+ AFUE- All SRU boilers are shipped standard as Energy star compliant

## High Output Ratings

Product Code	Number of Sections	Heating Capacity (MBH)	INPUT (MBH)	Net AHRI Rating Output	Length (Inch)	Coil Size (GPM)	Water Content (gal)	Weight (Lbs)	AFUE Efficiency (%)
SRU30H	3	140	161	122	24.5"	3.5	11.25	337	86.3
SRU40H	4	171	196	149	29.5"	4.5	14.125	425	86.5
SRU50H	5	208	238	181	34.5"	5	17	509	86.5

H designates High output ratings @ 86%+ AFUE- To achieve high output ratings, a burner nozzle or setup change is required.(sold separately)

All dimensions are in inches.

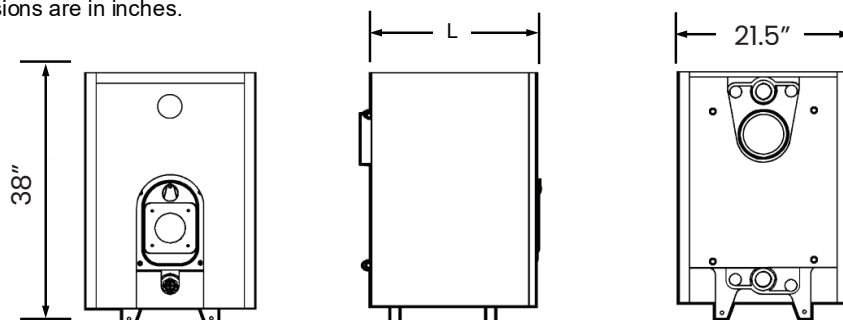



## 2. Boiler Block Assembly

All SRU series boilers are shipped from the factory in assembled boiler blocks.

### Boiler Block Assembly:

1. Front Section	10. Plug gasket	18. 3/4" Plug (Sight Hole)
2. Rear Section	11. 1/4" X 1 1/4" Bushing	19. Boiler Door Hinge (4 pieces)
3. Intermediate Section	12. Boiler Swing Door	20. Hinge Pin (Qty 6)
4. Steel Push Nipples(Top)	13. Upper Cleanout Plate Insulation	21. Boiler Body Hinge Bolts (Qty 2)
5. Steel Push Nipples(Bottom)	14. Upper Cleanout Plate Gasket	22. Door Hinge Mounting Bolts (Qty 2)
6. Tie Rod	15. Burner Door Insulation	23. 6" Boiler Breeching
7. Tie Rod Nut	16. Door/Cleanout Stud (Qty 7)	24. Upper Cleanout Plate
8. Tie Rod Washer	17. Burner Door Gasket	25. Boiler Baffles
9. 1 1/4" Plug		

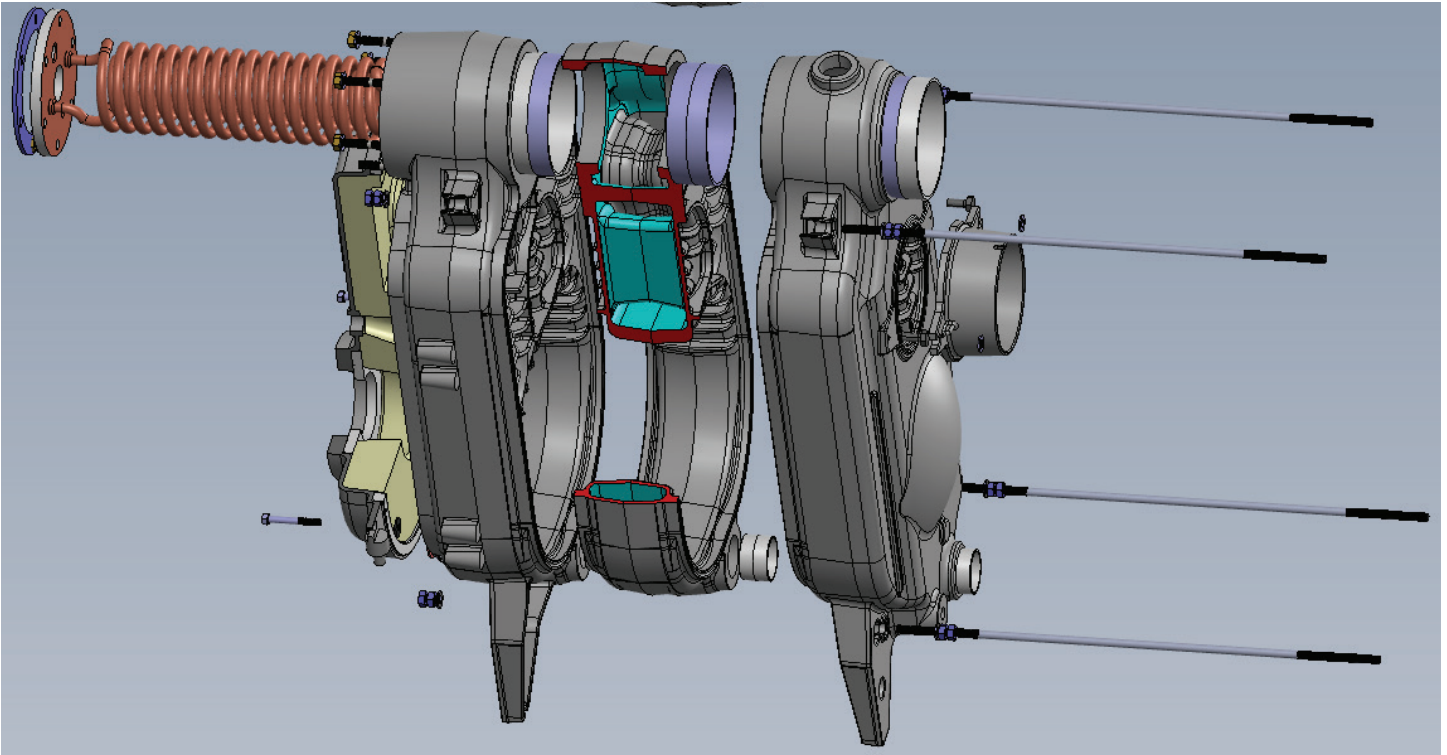



### 3. Boiler location

The following are the minimum clearances to construction or combustible materials:

Standard Installation Clearances					
Above	Front	Sides	Rear	Chimney Connector	Below
24"	12"	9"	2"	9"	Non Combustible

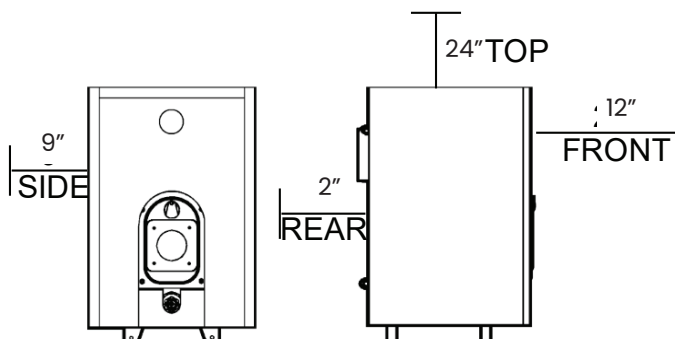

### DANGER

The boiler must be located on a non-combustible floor. A smooth, level concrete floor is recommended. Locate the boiler as close as possible to the chimney. If the boiler is installed on combustible flooring, consult local authorities for proper method of covering floor. The boiler must not be installed on carpeting.

**Caution: Do not store or use flammable materials, chemicals or flammable liquids, especially gasoline, in the vicinity of this heating appliance.**

If the boiler is to be installed in a "direct vent" configuration, please refer to the Direct Vent Addendum supplied with the Direct Vent Kit.

PROVISIONS FOR COMBUSTION AIR AND VENTILATION AIR MUST BE IN ACCORDANCE WITH SECTION 5.3, "AIR FOR COMBUSTION AND VENTILATION", OF THE NATIONAL FUEL GAS CODE, ANSI Z223.1, OR APPLICABLE PROVISIONS OF THE LOCAL BUILDING CODES.

**DO NOT INSTALL THE BOILER UNTIL PROPER COMBUSTION AIR HAS BEEN ARRANGED.**

### WARNING

Boiler is certified as an indoor appliance. Do not install boiler outdoors or locate where it will be exposed to freezing temperatures. NOT FOR MOBILE HOME INSTALLATIONS

## 4. Installation of Boiler Trim Components

### Trim Kit Components

WT-1 and WT-2 Trim Kits Include:

1 - Hydrostat 3250TC High Limit w/LWCO	1 - 3/4" Plugs
1 - Combo pressure/temp gauge	1 - 3/4" 90° Elbow
1 - 3/4" X 3" Nipple	1 - 3/4" Electrowell
1 - 30 PSI pressure relief valve	1 - Cera-Fiber Pad (FOR BOTTOM OF BOILER CHAMBER)
1 - 3/4" Boiler drain	

WT-1 Has 4 GPM Coil	WT-2 Has 5 GPM Coil
---------------------	---------------------

### LT "Less Tankless" Trim Kit

Uses the same components as the WT "With Tankless" Trim Kit except the Hydrostat Controller has been changed to the Hydrolevel 3250Plus to allow for the use of an outside sensor

USE ONLY THE ULC LISTED BOILER COMPONENTS AND UL/CSA LISTED OIL OR GAS BURNER COMPONENTS SUPPLIED WITH THE BOILER SYSTEM.

Please refer to the figure below for Barometric Damper location for either oil or gas and to the next page for the proper location of the trim components.

**(Required for Gas systems only)**

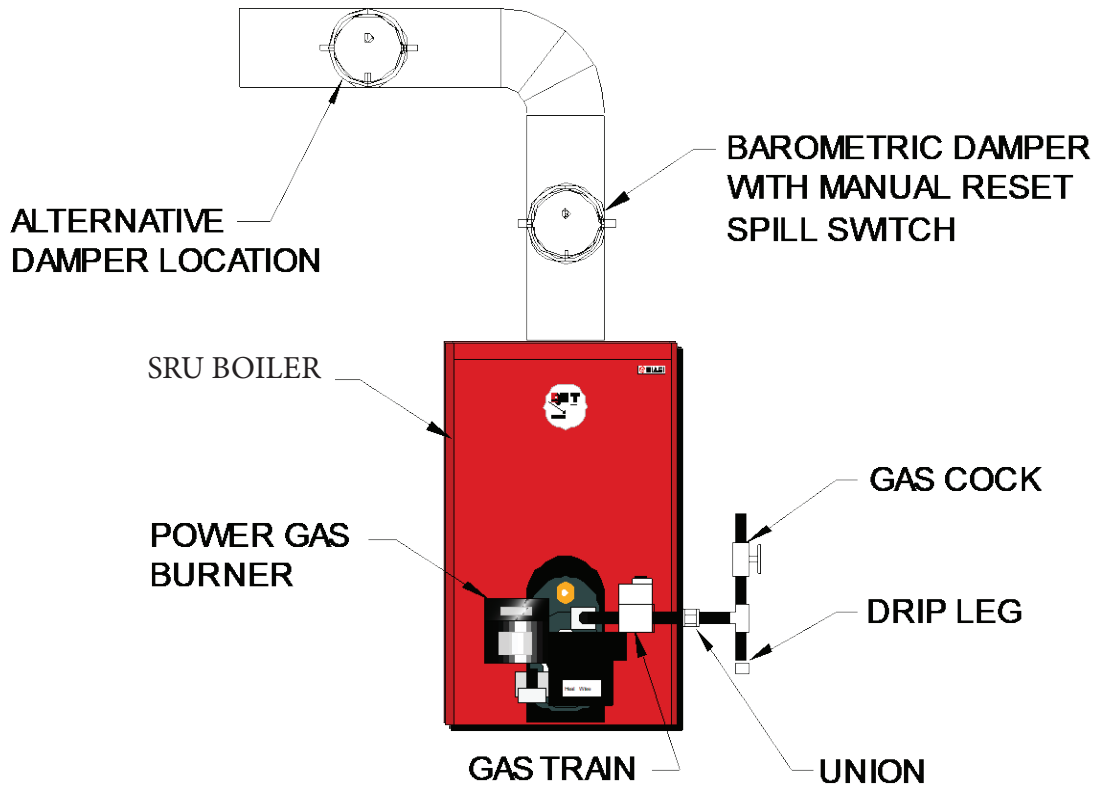

**NOTE: See Page 21 for available gas burners in North America**

## 4. Installation of Boiler Trim Components (Continued....)

1. For the SRU LT "less Tankless" boiler, Install Hydrolevel 3250Plus Electrowell in upper left or right rear 3/4" tappings. For SRU with Coil, Use the 3/4" tapping on the front coil plate. All tapings and joints should be sealed with piping compound. The boiler high limit can be adjusted up to 200o F, and should be set to the desired temperature by the installer. The differential is also adjustable between 5 and 30 degrees. It should be set as close to 30 degrees as possible to prevent short cycling of the burner. If you are installing a Hydrostat 3250plus, screw the unit to side panel of the boiler as close to the immersion well as possible using the tabs on the hydrostat. Run the sensor from behind the aquastat to the immersion well and fix it according to manufacturer's instructions.
2. Install Pressure Relief Valve in opposite, upper rear tapping using 3" nipple and 3/4" elbow.
3. Install 3/4" boiler drain in lower right rear tapping.
4. Install combination pressure/temperature gauge in the upper front tapping. The gauge must be tightened using a wrench and not your hand.
5. **Place the 12" x 12" Cera-fiber blanket on the floor of the combustion chamber of the boiler**

**Boiler Tapping Diagram:**

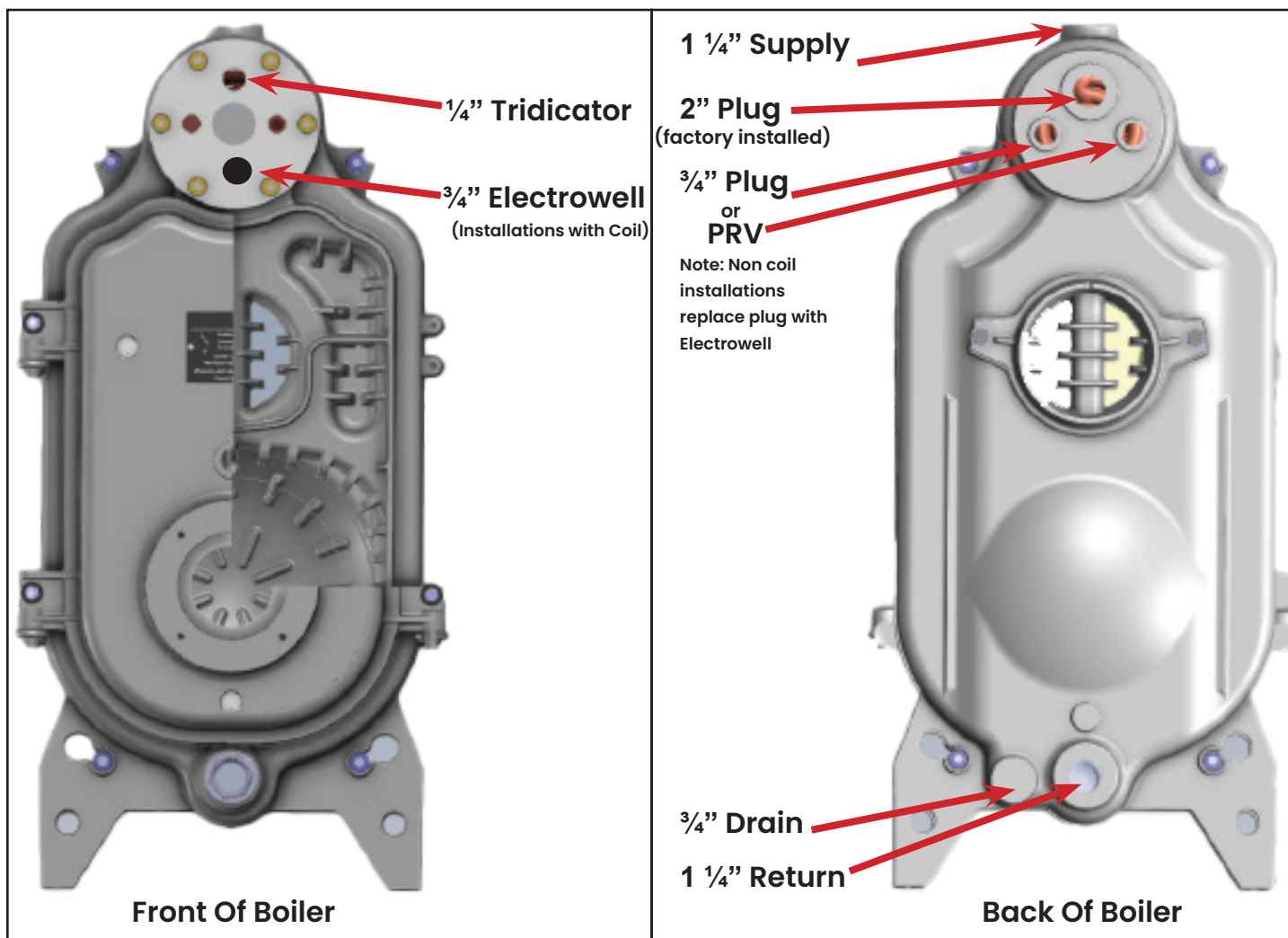

## 5. Tankless Coil Installation

### **DANGER-SCALD HAZARD**

The control supplied with this boiler is not intended to provide accurate control of the domestic water temperature leaving the tankless heater. An installer supplied, ASSE 1017 or ASSE 1070 certified tempering valve is therefore REQUIRED as part of this boiler's installation.

- Select, and install tempering valve in accordance with the valve manufacturer's instructions and applicable local codes. In the absence of such codes follow the Uniform Plumbing Code (IAPMO/UPC-1). Also note that additional tempering valves may be required at the fixtures themselves.
- Adjust low limit and tempering valve to the lowest practical setting.
- Feel water before showering or bathing.

If this boiler is installed with an optional tankless heater, pipe the heater as shown in Figure 1.1. The components in this system and their functions are as follows:

- 1) ASSE 1070 or ASSE 1017 Listed Tempering Valve (Required) - Like all tankless heater equipped boilers, the control provided with this boiler is not designed to regulate the domestic water temperature exiting the tankless heater. A tempering valve is therefore required for domestic water temperature control. Select and install this valve in accordance with the valve manufacturer's instructions and applicable codes. Note that some codes require additional tempering devices at some of the fixtures as well.
- 2) Flow Restrictor (Recommended) - If water is drawn from the tankless coil at a rate in excess of the rating in Table 1.1, the temperature of the hot water may be too low to be of use. The use of a flow restrictor will help prevent this problem by limiting the rate at which water can pass through the tankless heater. If possible, locate this restrictor at least 3 feet from the tankless heater inlet so that it is not subjected to excessive temperatures when no water is flowing through the coil.
- 3) DHW Pressure Relief Valve (Recommended / Consult Local Codes) - Limits the pressure in the tankless heater and piping. Use an ASME constructed valve designed for domestic water service, such as the Watts #3L or #53L. Note that this is a pressure relief valve, not a T&P valve. Select a valve with a pressure setting less than or equal to the working pressure marked on the tankless coil. Pipe the discharge to a safe location using piping the same size as the discharge connection on the valve.
- 4) Hose Bib Valves (Recommended) - These valves permit the tankless heater to be periodically "backflushed" to remove sediment.
- 5) Globe or Ball Valve (Recommended) - Used to aid in back flushing the tankless heater and to isolate the DHW piping if it must be serviced. In addition, the upstream valve may be used to limit the DHW flow if necessary.
- 6) Unions (Required) - Tankless heaters may require periodic gasket replacement or other maintenance which requires removal of the heater from the boiler. Install unions anywhere in the tankless heater piping that will facilitate removal of the heater.

## 5. Tankless Coil Installation (continued...)

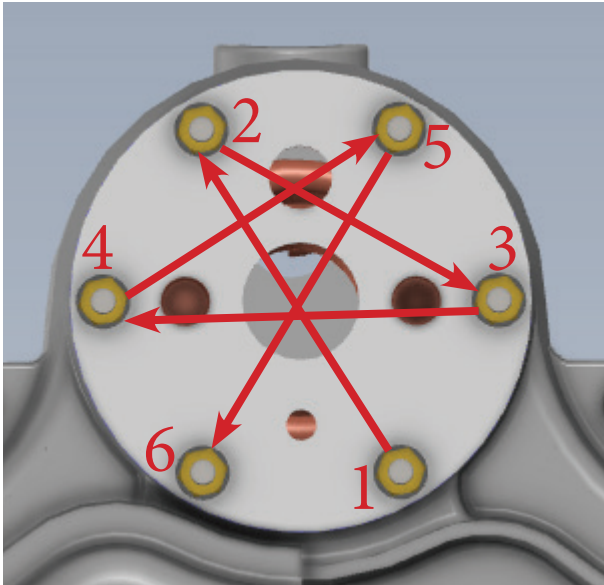

When installing the coil:  
Use cross pattern tightening

Using a **17mm** Socket/wrench:  
Start to tighten at spot 1, then move to spot 2 and so on.....  
**DO NOT OVER TIGHTEN!**

**NOTE: After boiler is warmed up to temperature, retighten the nuts in the same cross pattern.**

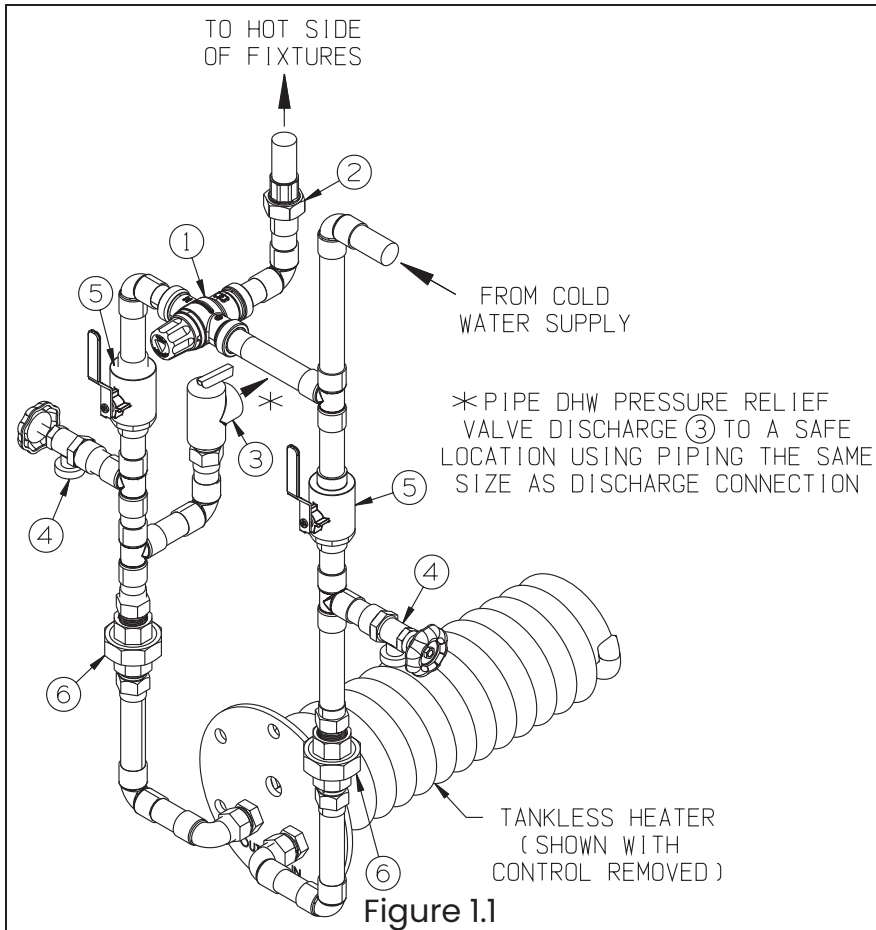
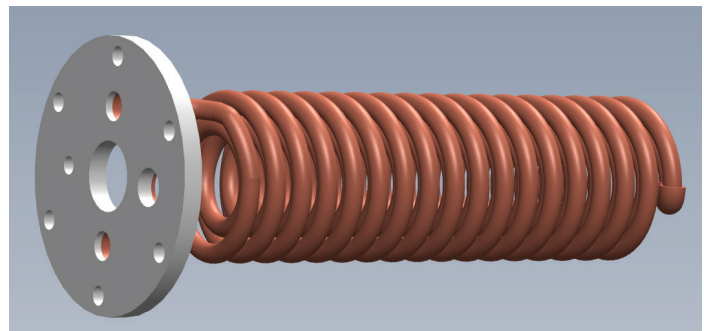

**NOTE:** Recommended initial low limit setting is 160°F

### Coil cleaning and domestic water quality recommendations:

100mg/l max hardness 6.5-8 PH  
100 PPM or less TDS  
1.5mg/l max free chlorine  
Recommend flushing coil with a compatible coil cleaner solution annually.

## 6. Piping The Boiler

All piping must conform to state and local codes. Page 11 shows the location and size of the boiler tapings. It is recommended to install unions and gate valves at the inlet and outlet of the boiler, so it may be readily isolated for service.

A low water cut off is required if the boiler is installed above the level of radiation. Even if the boiler is installed below the level of radiation it is strongly recommended that a low water cut off be installed. Install manual and/or automatic air venting devices at the high points in the system to eliminate trapped air. The weight of all piping should be supported by suitable hangers and floor stands, not by the boiler's purging/expansion station. Clearance for hot water pipes are 1 inch to combustibles. The make-up water line must be piped into the boiler and be fitted with a backflow preventer and a pressure reducing valve to reduce line pressure to 10 to 15 psi.

In the case of a gas installation, the boiler should be installed such that the gas ignition system components are protected from water (dripping, spraying, etc.) during appliance operation and service (circulator replacement, condensate trap, control replacement, etc.).

If the boiler is to be used in conjunction with a chilled water system, it must be piped with the appropriate valves to ensure the chilled medium does not enter the boiler. If the boiler is connected to heating coils in an air handling system, where the coils could be exposed to cold air circulation, provisions for freeze protection control must be installed. The boiler must have flow control valves or other automatic means to prevent gravity circulation of the boiler water during the cooling cycle.

NOTE: If the heating system is to be filled with antifreeze, use only formulations expressly made for hydronic heating systems (such as propylene glycol). Do not use automotive types of antifreeze (ethylene glycol). Use of antifreeze will alter system output and characteristics. Consult a factory representative for details or assistance.

## SAFETY RELIEF VALVE

1. The safety relief valve should be piped into one of the two upper 3/4" tapings in the rear of the boiler
2. The relief valve should be installed using the hardware supplied in the trim kit without valving between the PRV and the boiler.
3. Pipe the discharge for the safety relief valve with copper tube to within 4" from the floor and make sure installation of the pipe conforms to local codes.



## 7. Intake Venting

1. Be certain adequate air is available for combustion and ventilation.

a.) **Boiler located in unconfined space:**

Installation in large areas, such as basements, can usually be assumed to provide sufficient air.

b.) **Boiler located in confined space : (See Figure A. on page 14)**

**If all air for combustion and ventilation is to come from within the building:**

Two (2) openings shall be provided with one (1) opening commencing within 12 inches of the ceiling and one (1) opening commencing within 12 inches of the floor of the enclosure. These openings shall not be located closer than 3 inches from either the top or bottom of the enclosure and shall be open to areas connecting freely with the outdoors. The area of each opening shall not be less than one square inch per 1000 BTU/HR. of total input rating of all appliances within the enclosure; with a minimum of 100 square inches for each opening.

**If all the air for combustion and ventilation is to come from outside the building:**

Two (2) openings shall be provided with one opening commencing within 12 inches of the top and an opening commencing within 12 inches of the bottom of the enclosure. These openings shall not be located closer than 3 inches from either the top or bottom of the enclosure, and shall connect directly or by ducts too the outdoors. The area of each opening shall be equal to one square inch per 4000 BTU/HR of total input rating. If ducts are used to convey the air, vertical ducts require areas of one square inch per 4000 BTU/HR. Horizontal ducts require one square inch per 2000 BTU/HR. Ducts shall have the same cross sectional area as the full area of the louver openings.

The upper opening is essential for maintenance of proper air circulation with the boiler and to maintain proper control temperatures. When a duct is used for ventilation, check for louver free net area and correct for screen resistance to ensure that the sufficient ventilation area has been satisfied. DO NOT INSTALL THE BOILER UNTIL PROPER COMBUSTION AIR HAS BEEN ARRANGED.



## 7. Intake Venting (Continued...)

### c.) **Boiler located in a room under negative pressure:**

If the boiler is to be installed within a home where the operation of exhaust fans, attic fans, kitchen ventilation systems, clothes dryers or fireplaces may create severe negative vent pressures causing unsatisfactory combustion and venting, special provisions should be made for additional make-up air to supply the other air requirements. If building is of tight construction, combustion air requirements may not be met and combustion air ducts from outside may be necessary. Please refer to NFPA No. 31.

Tight Construction (as defined by ANSI Z223.1):

1. Walls and ceilings exposed to the outside atmosphere have a continuous water vapor retarder with a rating of 1 perm or less with openings sealed with gaskets, etc..
2. Weather-stripping has been added on open able windows and doors, and caulking or sealants are applied to areas such as: joints around windows and door frames, between sole plates and floors, between wall ceiling joints, between wall panels, at penetrations for plumbing, electrical, and gas lines, and in other openings.

If the building is of tight construction, air openings must be provided from the outside, with appropriate sizing depending on amount of BTU/HR as shown in Figure A. The boiler room must never be under a negative pressure, even if the appliance is installed as direct vent. Always provide air openings sized not only to the dimensions required for the firing rate of all appliances, but also to handle the air movement rate of the exhaust fans or air movers using air from the building or boiler room.

**Figure A.**

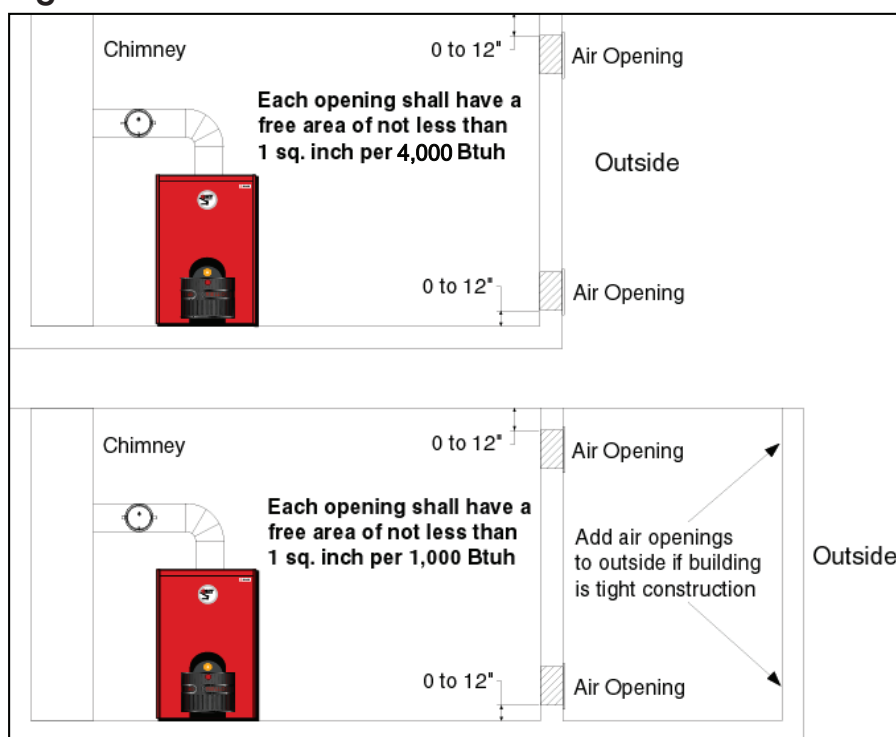

## 8. Exhaust Venting

The SRU boiler is a high efficiency unit that requires proper venting. The boiler must be vented to the outdoors by means of a lined masonry or a approved pre-fabricated chimney of the size and height recommended by the manufacturer or by a listed "power venting" unit which provides draft by mechanical means. In many installations, particularly older interior and most exterior chimneys, a corrosion resistant liner should be installed and may be required by code. Please consult the liner manufacturer for the appropriate chimney liner.

The flue-gas exit of the chimney must be located at least 24 inches above any part of the building structure within 4 feet of the chimney. Be sure the chimney and smoke pipe won't become obstructed by rodents, bird nests, soot buildup, chimney liner deterioration, etc.. If using a "power venter" system, it is suggested that it should be installed on the leeward side of the house. (Please consult with the manufacturer of "power venter" for requirements concerning clearances from combustibles and distances from doors and windows.) The "venter" must be installed by a licensed burner mechanic and done in accordance with local codes. This is a very low stack temperature boiler so caution should be used when connecting to an outside built chimney. Proper chimney sizing is important to prevent damage due to possible condensation from low flue gas temperatures. Should you have concern that the flue gases could condense, you should consider lining the chimney or using a listed, "power venting" or the QHT direct vent system. If "power venting" is used to discharge flue gases, then the power vent unit should be equipped with a postpurge control such as a delay-off, timing control to prevent problems with fogging and nozzle post drip. If the boiler is installed as a direct vent unit, it must be installed using a direct vent kit supplied by QHT Inc.

The exhaust pipe connection from the boiler to the chimney should be as short as possible, with a minimum number of elbows **\*\*For optimal sound control us 18" of straight pipe off breech collar before any 90' fittings.** The vent pipe must have a vertical rise of at least 1/4 inch per foot of horizontal run. The vent pipe must be of the same diameter as the flue outlet on the boiler. The chimney connector should have a minimum thickness of 26 gauge, corrosion resistant (galvanized) steel, and be assembled with a minimum of three (3) sheet-metal screws in each joint. In most one and two story houses, a barometric draft control is not required as the SRU is designed to be pressure fired. However in high draft situations which exceed the flue gas resistance through the boiler, a barometric draft control is recommended. The over fire draft should be positive and between 0 and .06 inches of water column. The draft at the breech should be enough to overcome the resistance through the boiler.

## 8.1 Common Exhaust Venting

Common vent exhaust:

If this boiler is replacing one which was part of a common venting system, it is likely that the vent is too large to vent the appliances still attached to it. To prevent this, at the time of removal, the following steps shall be followed with each appliance remaining connected to the common venting system. Place each appliance in operation, while the other appliances remaining connected to the common venting system are not in operation.

1. Seal any unused openings in the common venting system.
2. Visually inspect the venting system for proper size and horizontal pitch and determine there is no blockage or restriction, leakage, corrosion or other deficiencies which could cause an unsafe condition.
3. Insofar as practical, close all building doors and windows and all doors between the space in which the appliance remaining connected to the common venting system is located and other spaces of the building. Turn on any appliance not connected to the common vent system. Turn on all exhaust fans except for summer exhaust fans. Close the fireplace damper if applicable.
4. Place in operation the appliance being inspected. Follow the lighting instructions. Adjust thermostat so appliance will operate continuously.
5. Test for spillage at the barometric damper opening after 5 minutes of main burner operation. Use the flame of a match or candle, or smoke from a cigarette, cigar or pipe.
6. After it has been determined that each appliance remaining connected to the common venting system properly vents when tested as outlined above, return the doors, windows, exhaust fans, fireplace dampers and any other gas-burning appliance to their previous condition of use.
7. Any improper operation of the common venting system should be corrected so the installation conforms with the National Fuel Gas Code, ANSI Z223.1 and/or CAN/CGA B149, Installation Codes. When resizing any portion of the common venting system, the common venting system should be resized to approach the minimum size as determined using the appropriate tables in Part 11 of the National Fuel Gas Code, ANSI Z223.1, and/or CAN/CGA B149, Installation Codes.

## 8.2 Gas Venting

For boilers connected to gas vents or chimneys, vent installations shall be in accordance with part 7, Venting of Equipment, of the National Fuel Gas Code, ANSI Z223.1 or Section 7, Venting Systems and Air Supply for Appliances, of the CAN/CGA B149, Installation Codes, or applicable provisions of the local building codes.

Vent connectors serving appliances vented by natural draft shall not be connected into any portion of mechanical draft systems operating under positive pressure.

## 9. Burner Setup

Good, reliable operation with a minimum of service, starts with attention to the small details:

**Note:** Use a combustion analyzer to set up a Oil/Gas appliance.

### Oil:

1. Setting the nozzle position and electrodes to the manufactures specs using the manufacturer's gauges.
2. Installing a quality micron filter at the burner.(replace old oil lines and clear sludge)
3. Making careful/tight flare connections, without couplings, on oil suction line.
4. Checking fuel pump pressure is set to specs on following page.
5. Checking draft at the breeching to insure it is adequate to overcome flue gas resistance. (-.02 to -.04 in. w.c.)
6. Setting the air band properly with well maintained instruments. A good target is 12% to 12.5% of (CO<sub>2</sub>).
7. To achieve the rated efficiency level the CO<sub>2</sub> should be set to 13.2% and CO should be less than 50ppm

To ensure proper burner setup, gauges should be used to check things such as the pump pressure, CO<sub>2</sub> levels, CO levels, etc...

### Gas:

1. Checking the electrode, orifice size, and flame rod settings against manufacturer's specs to insure proper operation.
2. Installing properly sized gas piping according to BTU input required and length of gas line run.
3. **Making sure there is proper manifold pressure before and after the gas valve using a calibrated manometer.**
4. Checking draft at the breeching to insure it is adequate to overcome flue gas resistance. (-.02 to -.04 in. w.c.)
5. Setting the air band properly with well maintained instruments. A good target is 9.5% to 10.0% of (CO<sub>2</sub>) for natural gas, or 11.0% to 11.5% of (CO<sub>2</sub>) for LP gas.

**NOTE:** Elevated CO during combustion analysis for the first few hours of operation from off gassing due to insulation in the combustion chamber.

## 9.1 Oil Burner Setup

This page is only for boilers using an oil burner. If a gas burner is being used, please refer to page 21 for the proper setup of the burner and gas lines.

### Energy Star Compliant Ratings

#### BURNER MANUFACTURER: CARLIN

Boiler Model:	SRU30	SRU40	SRU50	SRU60
Burner Model:	EZ-97550F	EZ-97550F	EZ-97550H	EZ-97550H
Firing Rate:	1.00	1.25	1.50	1.75
Insertion Depth:	4.5"	4.5"	4.5"	4.5"
Nozzle:	.85X70	1.00X70	1.25X60	1.50X45
Spray Pattern:	B	B	B	B
Pump Pressure:	150 psi	150 psi	150 psi	150 psi
Head/Bar:	2	3	4	2
Air Gate:	40%	45%	50%	40%

NOTE: EZ-Select replaces the former EZ-1 HP

#### BURNER MANUFACTURER: RIELLO

Boiler Model:	SRU30	SRU40	SRU50	SRU60
Burner Model:	40 F5	40 F5	40 F5	40 F10
Firing Rate:	1.00	1.25	1.50	1.75
Insertion Depth:	5"	5"	5"	5.875"
Nozzle:	.75X60	1.00X60	1.25X60	1.50X45
Spray Pattern:	W	W	W	B
Pump Pressure:	175 psi	160 psi	145 psi	170 psi
Head Setting/Bar:	1	3	4	2
Air Gate:	3	3.50	4	3

#### BURNER MANUFACTURER: BECKETT

Boiler Model:	SRU30	SRU40	SRU50	SRU60
Burner Model:	AFG	AFG	CF 375	CF 375
Firing Rate:	1.00	1.25	1.50	1.75
Insertion Depth:	4"	4"	6"	6"
Nozzle:	.85X60	1.00X60	1.25X60	1.50X60
Spray Pattern:	B	B	B	B
Pump Pressure:	140	140	140	150
Head Type:	L2	V1	V1	V1
Head /Air	STATIC PLATE (2-3/4")	0	0	3
Air Band:	9/1	10/0	9/0	10/2

### High Output Ratings

#### BURNER MANUFACTURER: CARLIN

Boiler Model:	SRU30H	SRU40H	SRU50H
Burner Model:	EZ-97550F	EZ-97550F	EZ-97550H
Firing Rate:	1.15	1.40	1.70
Insertion Depth:	4.5"	4.5"	4.5"
Nozzle:	.90X70	1.10X70	1.35X60
Spray Pattern:	B	B	B
Pump Pressure:	160 psi	160 psi	175 psi
Head/Bar:	2	3	4
Air Gate:	45%	50%	60%

NOTE: EZ-Select replaces the former EZ-1 HP

#### BURNER MANUFACTURER: RIELLO

Boiler Model:	SRU30H	SRU40H	SRU50H
Burner Model:	40 F5	40 F5	40 F5
Firing Rate:	1.15	1.40	1.70
Insertion Depth:	5"	5"	5"
Nozzle:	.85X60	1.10X60	1.35x45
Spray Pattern:	W	W	B
Pump Pressure:	175 psi	160 psi	160 psi
Head Setting/Bar:	2	3	2
Air Gate:	3	3.80	3

#### BURNER MANUFACTURER: BECKETT

Boiler Model:	SRU30	SRU40	SRU50
Burner Model:	AFG	AFG	CF 375
Firing Rate:	1.15	1.40	1.70
Insertion Depth:	4"	4"	6"
Nozzle:	.90X60	1.00X60	1.35X60
Spray Pattern:	B	B	B
Pump Pressure:	160	140	170
Head Type:	L2	V1	V1
Head /Air	STATIC PLATE (2-3/4")	3	3
Air Band:	9/0	10/2	10/2

## 9.2 Gas Burner Setup

This page is only for boilers using a gas burner. If an oil burner is being used, please refer to page 20 for the proper setup of the burner.

BURNER MANUFACTURER: CARLIN								
Boiler Model:	SRU-30		SRU-40		SRU-50		SRU-60	
Burner Model:	EZ-GAS		EZ-GAS		EZ-GAS		EZ-GAS	
Input (MBH):	140		175		210			
Fuel Type:	Nat	LP	Nat	LP	Nat	LP	Nat	LP
Orifice:	LET K (.281)	#2 (.221)	5/16 (.312)	7/64 (.266)	3/8 (.375)	LET O (.316)		
Manifold Pressure:	3.5"	3.5"	3.5"	3.5"	3.5"	3.5"		
Air Gate:	25%	25%	35%	43%	70%	80%		

Note: Consult burner manufacturers literature for gas manifold diagram and controls.

To determine how much gas is coming into the burner, or to set the gas meter correctly, the following formula can be used.

$$\text{Ft}^3/\text{hr} = [3600/(\text{sec. Per rev.})]*(\text{Size of gas meter})$$

The chart to the right can be used to determine the flow rate depending upon the time per revolution and the size of the gas meter dial.

Seconds Per Revolution	Size of Gas Meter Dial (Cubic Foot)		
	.5	1	2
20	90	180	360
25	72	144	288
30	60	120	240
35	51	103	206
40	45	90	180
45	40	80	160
50	36	72	144
55	33	65	131
60	30	60	120

## 10. Gas Line Piping

Gas supply piping is to be sized and installed properly in order to provide a supply of gas sufficient to meet the maximum demand without undue loss of pressure between the meter and the boiler. Consult with the *National Fuel Gas Code ANSI Z223.1* for proper sizing of gas piping for various lengths and diameters.

Locate a drop pipe adjacent to, but not in front of the boiler. Locate a tee in the drop pipe at the same elevation as the gas inlet connection to the boiler. Extend the drop line with a nipple towards the floor and cap to form a sediment trap. Install a shut off valve before the tee with sediment trap and a union after the tee before the combination gas valve.

When installing the boiler, make sure a pipe compound resistant to the action of liquefied petroleum is used. Check piping for leaks. Always check leaks with a water and soap solution. **DO NOT USE A FLAME FOR CHECKING GAS LEAKS**

The boiler and its individual shut-off valve must be disconnected from the gas supply piping during any pressure testing of that piping at test pressures in excess of 1/2 psi.

### Connecting gas supply piping to burner

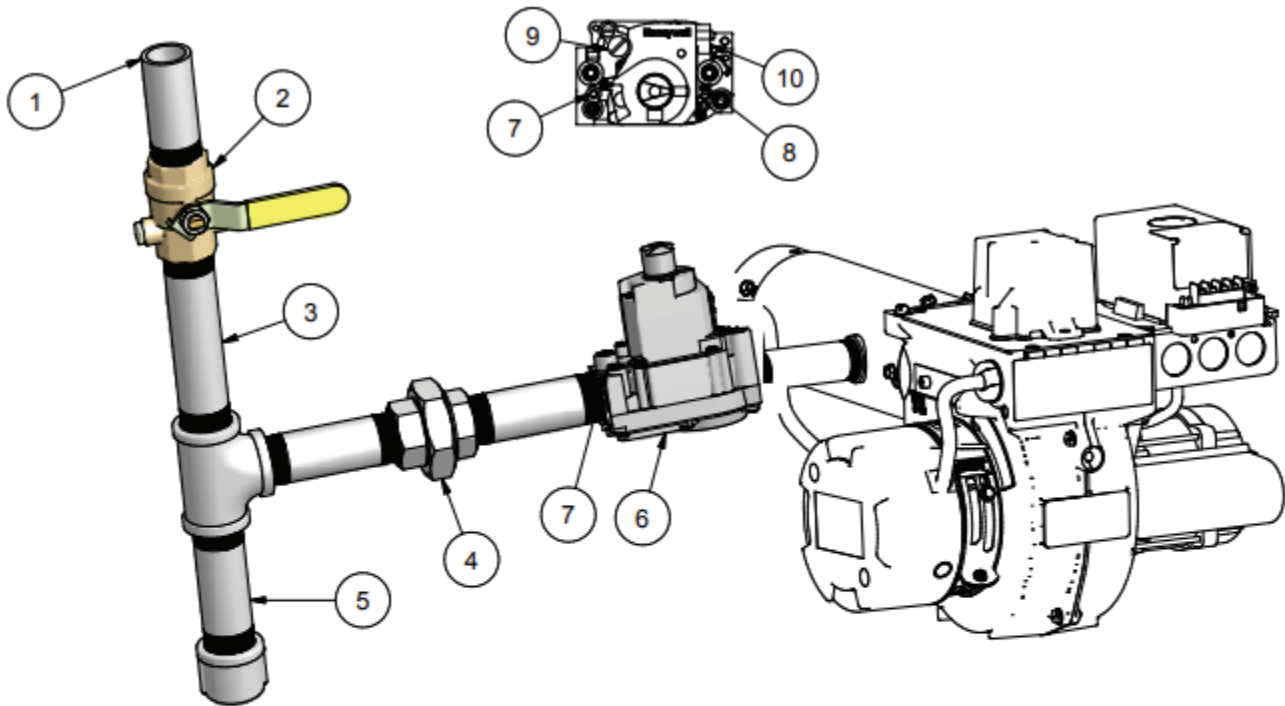

- |   |  |    |                                 |
|---|--|----|---------------------------------|
| 1 | Pipe to meter or branch  | 5  | Sediment leg                    |
| 2 | Main manual gas shutoff valve                                    | 6  | Burner combination gas valve    |
| 3 | Use clean, burr-free black iron pipe and malleable iron fittings | 7  | Upstream pressure tap, 1/8"     |
| 4 | Ground joint union   | 8  | Outlet pressure tap, 1/8"       |
|   |  | 9  | Gas regulator access screw      |
|   |  | 10 | Gas valve electrical connection |



## 11. Boiler Casing Assembly

Prior to installing casing, carefully remove the Boiler Serial Number SN tag attached to the tie rod. Keep the tag so it can be affixed to the casing. For ease of installation, the Boiler should be standing on a pad or on cinder blocks. Header piping, control wells, gauges, valves; all boiler tapings should have devices installed and the boiler should be pressure tested before wrapping the boiler block and mounting the casing panels on the boiler.

**Note: Do not install conduit or piping on or over top panel of the boiler.**

1. Wrap the boiler body with **Insulation Blanket**, foil side facing up. Fasten in place with the provided loop clips and strap OR use a piece of foil tape to hold the seam together.
2. Install the two **Side Panels** by hooking them onto the tie rods of the boiler. Start with the **BOTTOM** hooks first on an angle, then the tops hook on. (This requires you to loosen the nuts on the end of each tie rod)
3. Once side panels are in position, you can tighten the nuts on the tie rods.
4. Install **Back Panels**, they have hook tabs that go into slotted holes and slide down into position as shown, two panels top and bottom.
5. Install **Front Panels**, the tabs on the bottom of side panels guide front panel into position, the panel then snaps into the push pins.
6. Install **Top Panel**, top panel simply snaps down onto the pre installed push pins.
7. Affix the SN tag to the visible side of the casing along with energy guide and rating tag (all found in the envelope on tie rod of the boiler block)

### STEP 1



### STEP 2



### STEP 3



### STEP 4

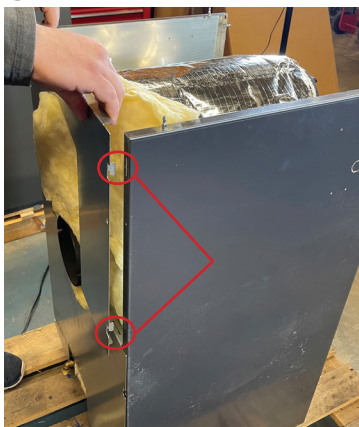

### STEP 5



### STEP 6



## 11.1 Baffle Installation

Remove these bolts to swing open front door.  
Using a 13mm Wrench/socket



Fig 10.1

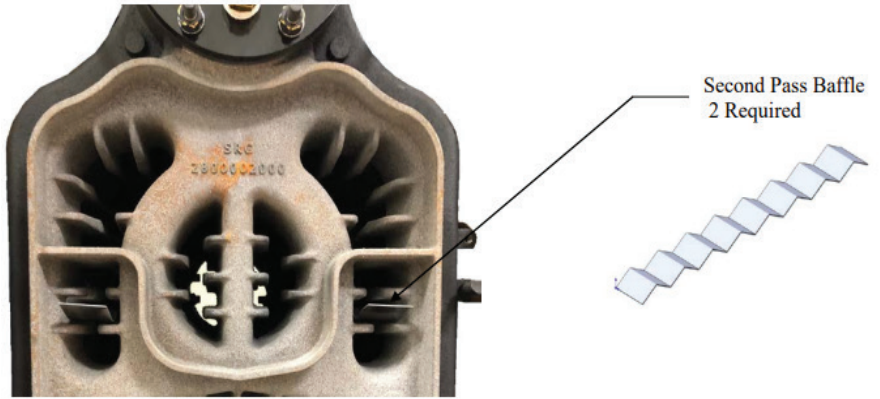

Fig 10.2

To achieve Energy Star efficiency, baffles have been installed in the second pass of the boiler. Two baffles are installed into each of the 2nd passes as shown in Fig. 10.2. For the baffle to fit correctly, the shortest leg of the baffle must be facing down. If the steady state flue temperature is too low, less than 325° F, the baffles may be removed to increase the temperature.

## 12. Wiring

The electricity to the boiler shall come from a dedicated breaker in the electric service box. A service switch should be mounted on the side of the boiler so the burner technician can service the burner and controls. The electrical wiring should be routed so as not to interfere with normal servicing of the boiler. Wiring done in the field between devices not attached to boiler shall conform with the temperature limitations for type T wire (63F/35C) or other specified wire as applicable when installed in accordance to manufacturer's instructions and wiring diagrams.

If an external electrical source is utilized, the boiler, when installed, must be electrically bonded to ground in accordance with the requirements of the authority having jurisdiction or, in the absence of such requirements, with the National Electrical Code, ANSI/NFPA 70 and/or the Canadian Electrical Code Part 1, CSA C22.1, Electrical Code.

Since the boiler is equipped with a swinging burner door, the supplied 48" long burner wiring harness with 4-prong quick disconnect plug needs to be used. The short end of the wiring harness needs to be wired to the burner following the respective burner wiring diagram in the subsequent pages of this manual. The long end of the wiring harness needs to be wired into the burner operating control located at the installers discretion.

Refer to pages 23 to 24 for oil wiring diagrams and page 25 for gas wiring diagrams. Priority wiring for Hydrolevel and Honeywell controls is on pages 26-27.

## 12.1 Hydrolevel Wiring

### Hydrolevel 3250 controller Low Water Cutoff

QHT has added a ground wire and provided a mechanical connection for grounding the Hydrolevel Immersion well back to the 3250 grounding lug.

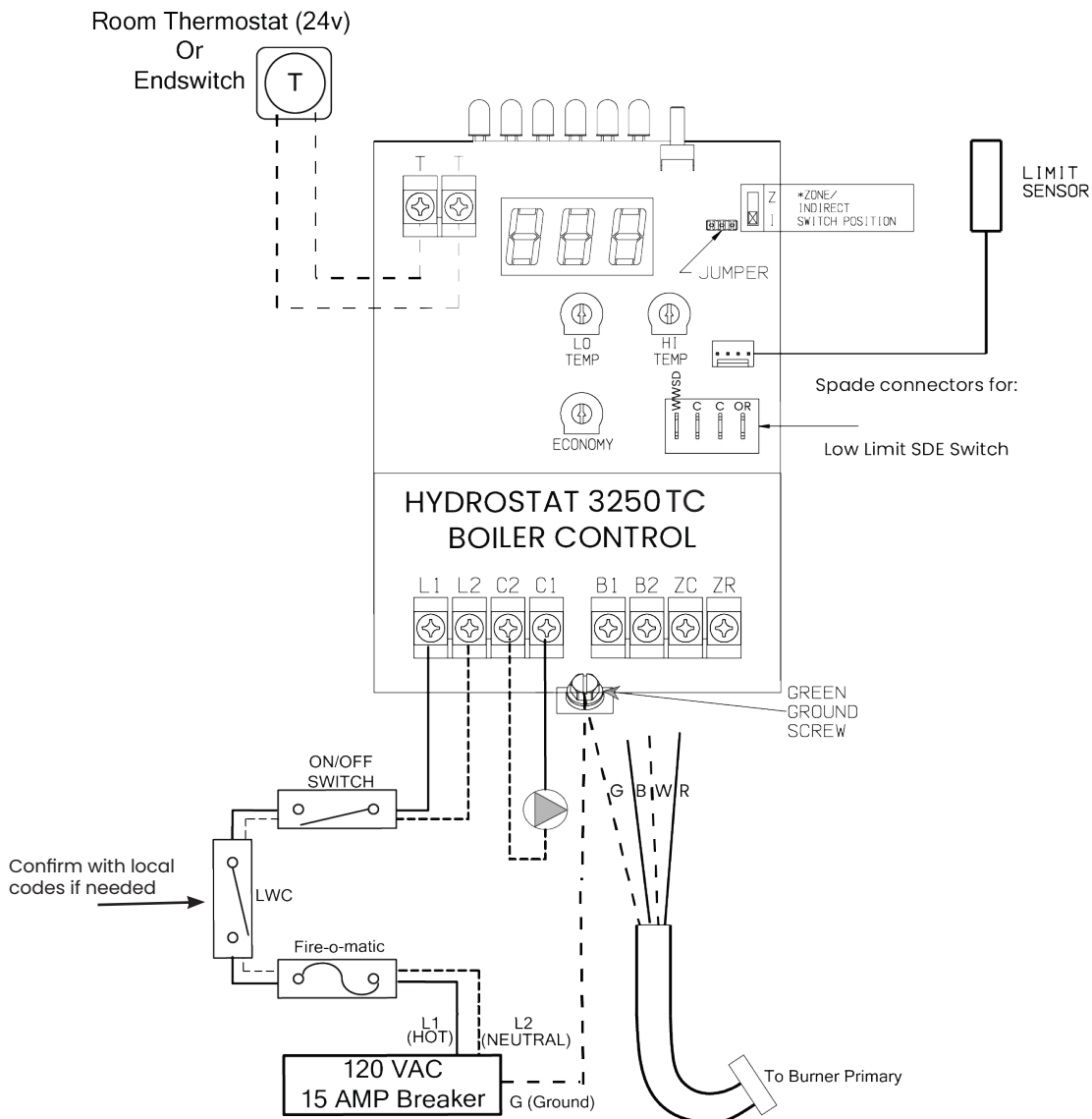
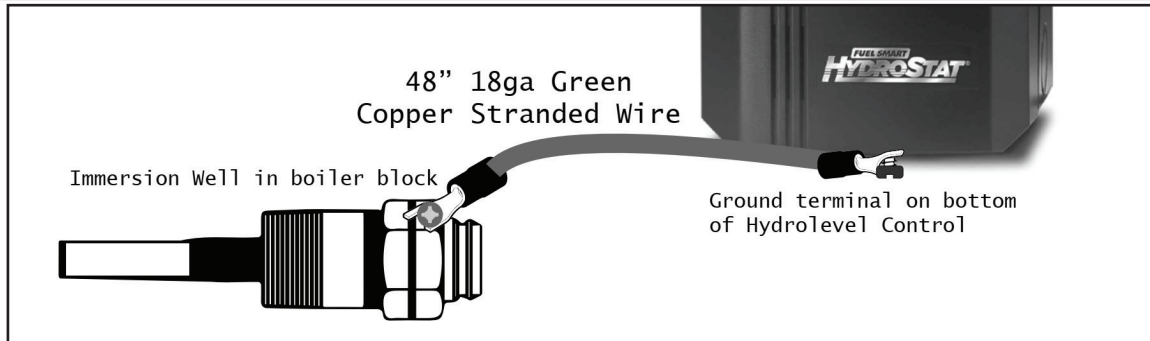

**NOTE: All wiring must be done in accordance with applicable state, local and national codes. Use only copper conductors.**

## 12.2 Oil Burner Wiring

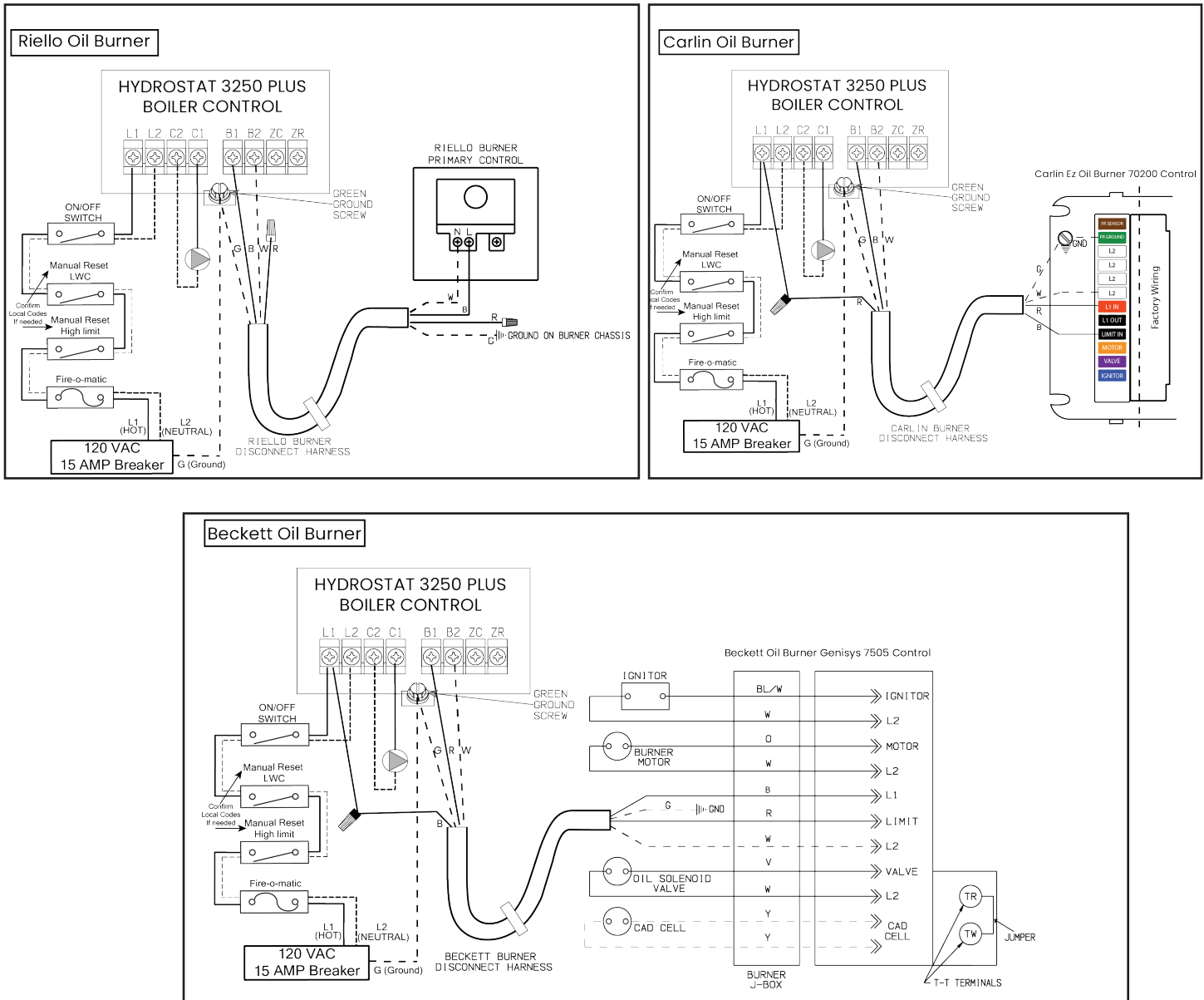

**NOTE: All wiring must be done in accordance with applicable state, local and national codes. Use only copper conductors.**

## 12.3 Gas Burner Wiring

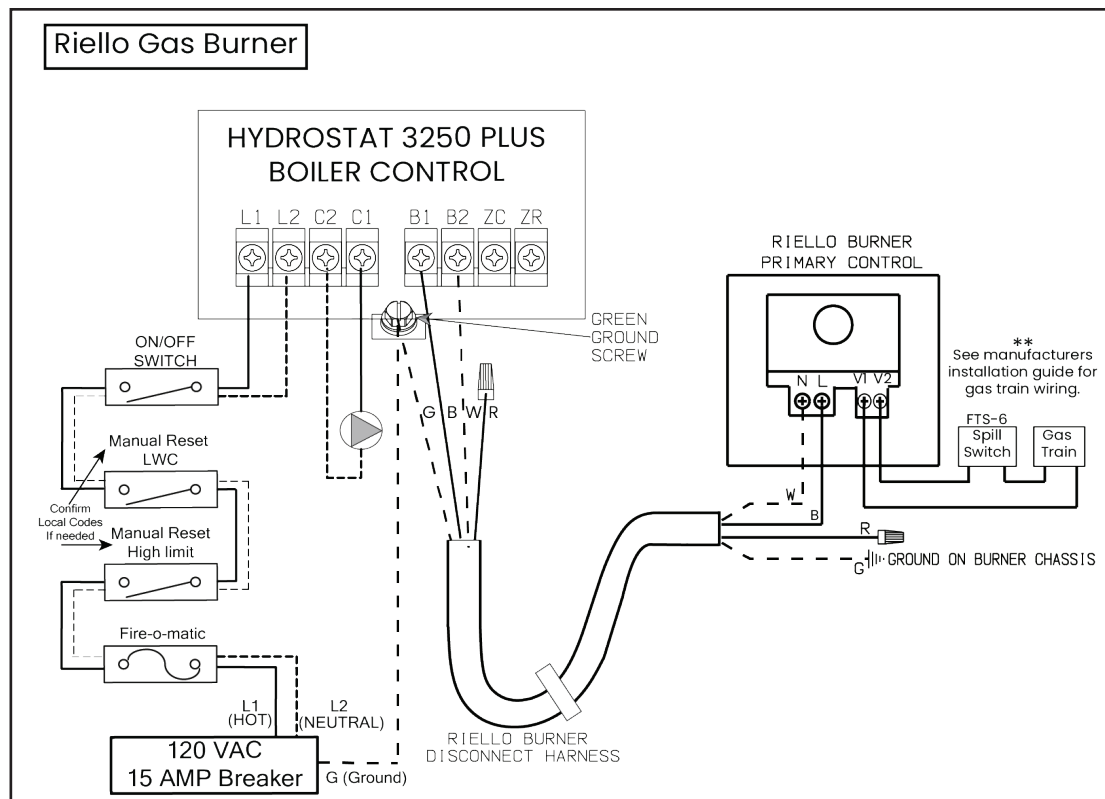
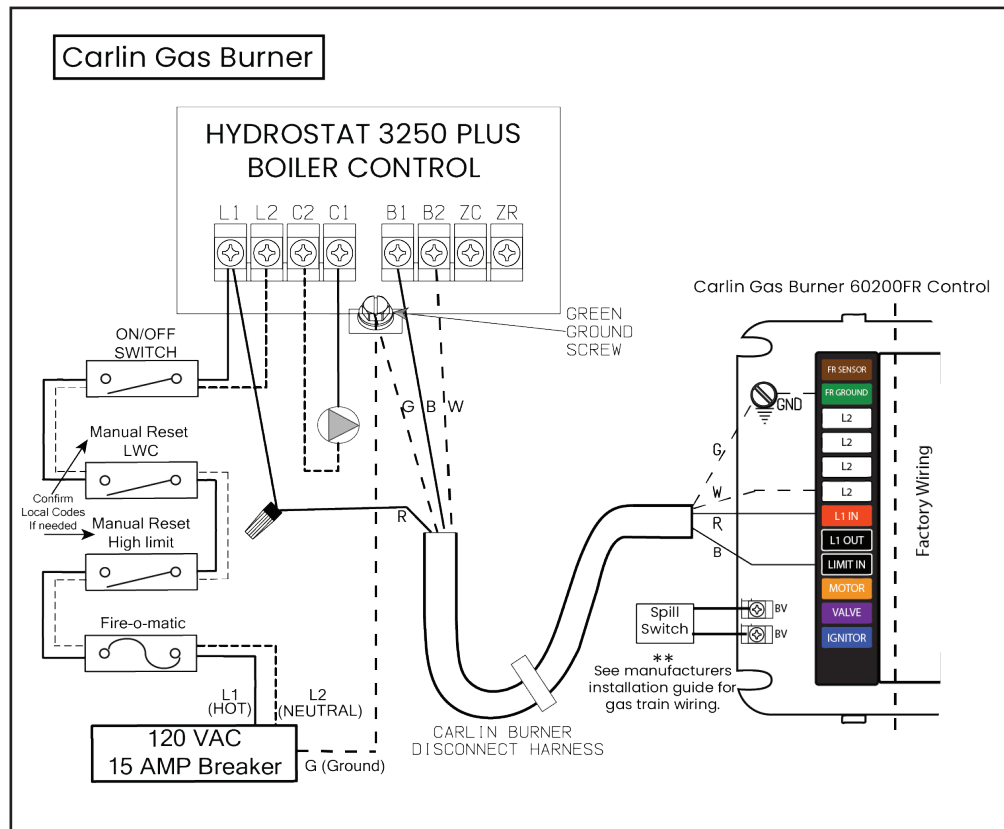

**NOTE: All wiring must be done in accordance with applicable state, local and national codes. Use only copper conductors.**



## 13 Smart Domestic Economizer

### How It Works:

The SRU-SDE functions by closing the circuit between OR and C when power is applied. The low limit side Hydrolevel 3250TC controller will be disabled. With the low limit disabled, the boiler will only run for a heating call when TT terminals are closed. The SDE is a normally open relay, to switch the LL disable feature on the relay must be closed (power energized to the SDE) When programming your SDE Cube control to a Smart Switch, power on equals DHW off.

### Control Options:

NO extra controls needed, just wire to C-OR, with C-OR contacts closed the Low Limit is disabled.

Make It Picture Perfect:

- Simple unpowered toggle switch mounted on the Saint Roch Universal or anywhere in the home.
- A mechanical or electronic timer connected to the SDE relay cube based on your occupancy.
- Smart house switch, plug Saint Roch's SDE Cube into a smart switch of your choice and control the DHW system from anywhere, Geofencing, Timers, Schedules.

### Installation is Easy!

What's included?

- (1) SRU-SDE
- (4) ¼" female spade connectors.

**Needed:** (2) lengths of 20-14awg wire.

1. Choose a convenient location to install your SRU-SDE.
2. Install your smart outlet or timer.
3. Connect the SRU-SDE to your 3250 Hydrostat C & OR terminals. Connections are non-polarized.
4. Remember, power to the SRU-SDE = NO DOMESTIC HOT WATER.

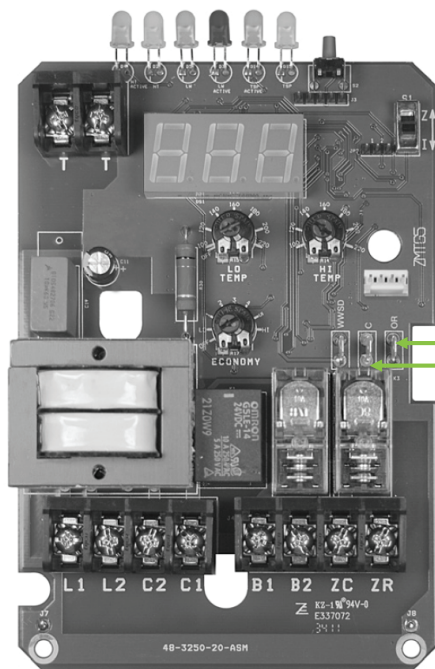

Hydrolevel 3250TC



Domestic Economizer Relay

## 14. Commissioning

Before a gas boiler may be put into operation and tested, it's gas connection must be leak tested. After installation of oil/gas-fired boiler, operation and performance tests shall be conducted to make certain that the burner is operating in an acceptable manner and that all safety controls and devices function properly. **It is critical that the high limit, low water cutoff and burner "cad cell" relay be checked for normal operation before leaving the job.**

### CAUTION

Label all wires prior to disconnection when servicing controls. Wiring errors can cause improper and dangerous operation.

## 15. Maintenance

**The SRU boiler system should be serviced once a year before each heating season.**

1. Turn off all electrical power to the boiler before inspecting and cleaning.
2. Disconnect the Molex plug at burner.
3. Remove the boiler front jacket panel by lifting vertically.
4. Open the swing door following previously described procedure.
5. If required remove any scale and soot deposits with a flexible flue brush. Vacuum all deposits from flue passages and chamber area. Be careful not to damage the door insulation.
6. Close swing door following previously described procedure. Check to ensure a proper seal between the door and the boiler has been made.
7. Eliminate any combustion gas leaks by replacing worn seals and gaskets.
8. Install jacket front panel.
9. Connect Molex plug for burner power.
10. Protect the heating system against freezing dangers with anti-freezes as required. Avoid intercommunications between domestic hot water and heating water since these antifreezes are toxic substances.
11. Check the piping system for leaks and repair as required. This will prevent water turnover with consequent risk of scale formation and corrosion in the boiler room.
12. Check for proper operation of the relief valve following the manufactures recommended procedure. Corrosion can build up rapidly at the valve seat and prevent its functioning as a safety device.

### **Burner**

Refer to the burner installation and operation manual provided for maintenance procedures.

### NOTICE

**Verify proper operation of high limit, low water cutoff and burner "cad cell" after servicing.**



## 16. Installer Notes

System Checklist		
Boiler Model #:	Serial #:	
Original Purchaser:	Installer:	
_____	_____	
_____	_____	
_____	_____	
Burner Checklist		
Burner Manufacturer:	Burner Fuel Type:	
Burner Model #:	Burner Serial #:	
Input:	Pump/Manifold Pressure:	
Nozzle/Orifice:	Head Setting:	Air Setting:

Burner Performance Test:	Install	Year 1	Year 2	Year 3	Year 4	Year 5
Gross Stack Temp						
Room Temp (Ambient)						
Net Stack Temp						
CO2						
O2						
Smoke Reading						
Combustion EFF%						

Comments/Notes:

---



---



---



---



---

# Warranty for Saint Roch Residential Cast-Iron Water Boilers

## First-Year Warranty

Quincy Hydronic Technology (QHT Inc) warrants that the cast-iron boiler and casing of Universal Series Residential Hot Water Boilers are free from defects in material and workmanship for one (1) year from the date of installation. If a defect is found within this period, QHT will replace the boiler block or casing at no cost to the original purchaser.

## Lifetime Warranty for Cast-Iron Boiler Blocks

Saint Roch warrants that the cast-iron sections and nipples of the Saint Roch Universal boilers are free from defects in material and workmanship for the lifetime of the original purchaser in a single-family home installation. If the Universal boiler block is found to be defective, QHT and Saint Roch will replace the original cast-iron boiler block.

## Warranty Conditions

This warranty is valid only if the boiler has been installed by a heating contractor whose primary occupation is the sale and installation of heating equipment.

## Covered Parts

This warranty applies to all materials supplied by Saint Roch and identified by QHT part numbers in its official literature. Other parts included in the casing, trim kit, or burner pack carry their own manufacturer warranties, and each manufacturer assumes responsibility for its respective products.

## Coil Warranty

The boiler coil is covered under warranty for one (1) year from the date of installation.

Note: Any part replaced under warranty is covered only for the unexpired portion of the original warranty.

## Owner Responsibilities

The boiler owner is responsible for the following:

- Ensuring proper installation, including pressure relief and pressure-reducing valves, as well as high-limit safety controls for closed systems.
- Arranging for qualified annual service to maintain proper operation.
- Ensuring that the boiler is installed with an approved burner and in compliance with all applicable codes and ordinances.
- Returning faulty components to Portsmouth, NH, with freight prepaid.

## Exclusions and Limitations

QHT Inc and Saint Roch shall not be held responsible for:

Components of the heating system not manufactured by Saint Roch or QHT.

Installation workmanship or any resulting unsatisfactory performance due to improper installation. Labor costs associated with the removal or replacement of faulty components. Improper burner applications, adjustments, control settings, maintenance, or care. Damage resulting from corrosion or leakage caused by the use of non-barrier plastic piping in the heating system.

## Warranty Limitations

This warranty extends only to the original retail purchaser and is valid only if the boiler remains installed at the original installation site.

Any implied warranties of fitness for a particular purpose and merchantability are limited to the duration of this express warranty.

QHT and Saint Roch expressly disclaim liability for any consequential or incidental damages arising from the breach of any express or implied warranty.

## Legal Rights

This warranty grants specific legal rights, which may vary by state.

## Claim Process

For warranty service, notify the installer, who will contact the distributor from whom the boiler was purchased. If this does not lead to corrective action, contact Saint Roch through QHT Inc. with supporting details for the warranty claim. All claims must be processed through appropriate trade channels. Direct contact with Biasi is not recommended for expedited claim resolution.

## Water Quality Requirements

To maintain warranty coverage, the water used in heating systems containing Saint Roch Boilers must meet the following criteria:

Total chloride and sulfate: Not to exceed 50 mg/L (50 ppm) • Total dissolved oxygen: Not to exceed 0.1 mg/L (0.1 ppm)

Water pH: Must be between 6.3 and 7.7 • Water hardness: Not to exceed 4.0 mval/L (200.17 ppm)

To register your boilers warranty please visit:  
[www.qhtinc.com/warranty-registration](http://www.qhtinc.com/warranty-registration)

Or Scan the QR Code:



LOCATE BOILER SERIAL NUMBER ON LOWER BOILER DRAW ROD IN ENVELOPE

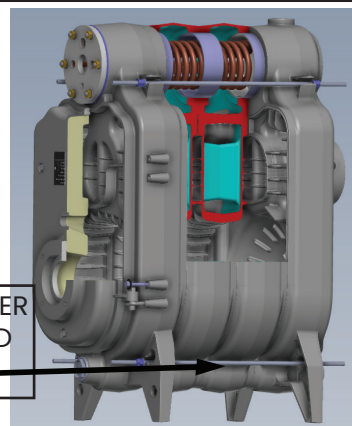

# Setting the Standard for Indoor Comfort, Environmental Integrity and Fuel Efficiency

QHT supplies the most durable, fuel efficient and environmentally sustainable boilers, radiators and convectors available. From its Portsmouth, NH warehouse facility, QHT assembles and distributes an extensive range of steel panel radiators, towel bars, boilers and fan convectors. In most cases, almost all products shown in this guide book can be shipped next day to anywhere in the US /Canada.

QHT has worked 35 years as a manufacturers' representative for HVAC products sold to wholesale distributors in the U.S. and Canada.

Customer service and support are the key to QHT's business. The staff at QHT will take care of your needs. In addition to providing specialized packaging and shipping services, QHT product support extends to giving on-site training seminars for fan convectors, radiators, boilers, burners and controls.

QHT represents several manufacturers of boilers and radiators. QHT remains committed to providing energy conservation with low environmental impact.



3560 Lafayette Rd  
Portsmouth, NH 03801  
800-501-7697  
[www.qhtinc.com](http://www.qhtinc.com)